

SURGE PROTECTIVE DEVICE PERFORMANCE AND CASCADED PROTECTION

SURGE PROTECTION NOTE 7

BY JEREMY LIELAND,
INDUSTRIAL SOLUTIONS
ENGINEER

INTRODUCTION

Surge Protective Devices (SPDs) Listed to UL 1449 are required to undergo Voltage Protection Rating (VPR) testing as a measure of their performance. This rating gives the user an idea of what voltage levels their equipment will see in the event there is a surge on the electrical system. This Tech Topic will examine Voltage Protection Ratings and what they mean to the end user. It will also discuss how cascaded protection offers a very effective multi-tier protection approach.

CAUSES OF VOLTAGE SURGE

There are two classifications of voltage surge, lightning surges and switching surges. Lightning surges can be caused by both direct and indirect lightning strikes. These surges typically produce the highest overvoltage, but are the least frequent. Switching surges are caused by events such as utility, capacitor bank and inductive load switching as well as short circuit clearing by fuses and circuit breakers. These events are typically lower in magnitude, but can still be significantly higher than the source voltage. Switching surges are very common in electrical systems.

SURGE PROTECTIVE DEVICE OPERATION

Most modern Surge Protective Devices utilize Metal Oxide Varistor (MOV) technology. MOVs are typically connected between an energized conductor and neutral and/or ground of the electrical system. An MOV is constructed of a semiconductor material, typically Zinc-Oxide, sandwiched between two conductive plates. During normal operation, the device has a very high resistance and only a few microamperes of leakage current will flow through it. In the event of a voltage transient, the increased voltage will break down the resistance of the device to allow it to conduct current away from the electrical circuit. The voltage level where significant current can be conducted is known as the breakdown voltage. This voltage is of particular interest as it is near where the Voltage Protection Rating will be.

TERMS

- **SPD:** Surge Protective Device

SURGE PROTECTIVE DEVICE PERFORMANCE AND CASCADED PROTECTION

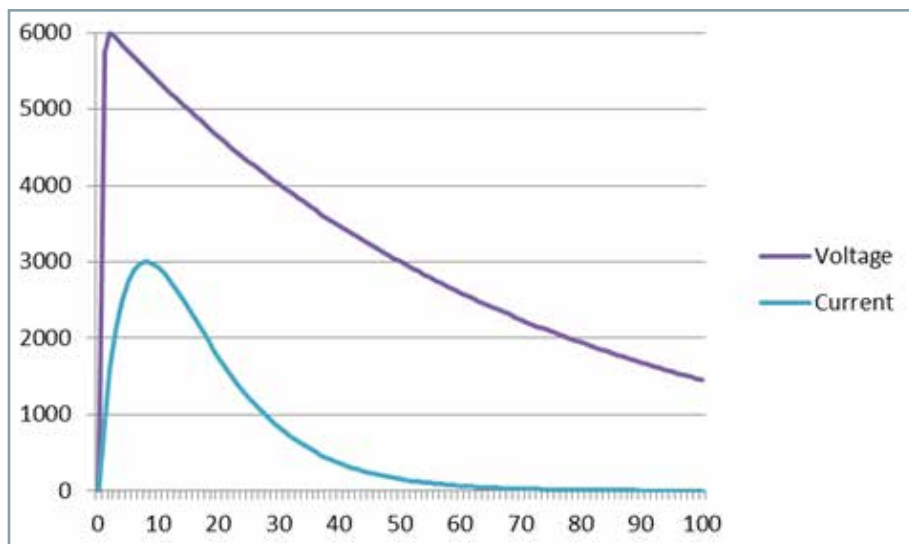

Figure 1: Combination Waveform

VOLTAGE PROTECTION RATING

The UL 1449 standard defines the requirements for testing to determine a device's Voltage Protection Rating. Each device is subjected to three "shots" of a 6kV and 3kA combination waveform (Figure 1). The resulting voltage that is allowed to pass through the SPD in the circuit is recorded and an average of the three shots is calculated. This average value is then compared to the values in table 79.1 of the standard and assigned the appropriate minimum voltage protection rating. For example, if the average of three shots is 539V, the voltage protection rating is 600V. Voltage protection ratings are important as they define the protection level for a very high overvoltage event with its corresponding current. The VPR should be at a value that is something less than five times the rated voltage in order to be effective at protecting downstream electronics from overvoltage. The main reason for a five times limitation is the Information Technology Industry Council's (ITIC) voltage tolerance curve (Figure 2) which describes the tolerance region for electronic devices. This curve was originally created for 120V systems, but can be useful to predict power quality effects on industrial power system equipment as well. The beginning point on the curve is 500% voltage for 0.01 cycles. Considering that voltage surges are short time events, typically shorter in duration than 0.01 cycles, it can be inferred that events beyond 500% voltage will cause damage to equipment.

SPD PERFORMANCE AT LOWER VOLTAGES

As stated above, the VPR rating is the devices' performance at one specific level of voltage surge. The UL test levels are those that would be more likely to occur in the event of a lightning strike. The events caused by switching surges as discussed previously, can still produce significant over-voltages, but typically less than those of a lightning surge. We will examine the SPD response to high frequency, low magnitude events to see if the pass-through voltage stays low enough to protect equipment.

Two SPD samples were chosen, one for 120V circuits and one for 480/277V circuits. The samples were connected to a combination wave generator with #10 AWG, which is a typical wire size for the application. After connection, each sample was subjected to voltages ranging from 6.75kV down to a voltage near its VPR rating. Each successive test reduced the input voltage waveform by 50%. The testing was stopped when the surge current became insignificant.

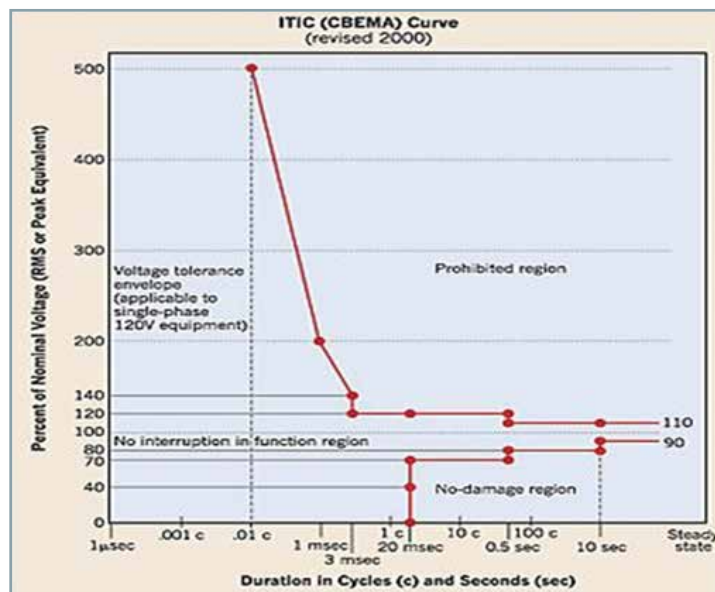

Figure 2: ITIC (CBEMA) Voltage tolerance curve

SURGE PROTECTION NOTE 7

SURGE PROTECTIVE DEVICE PERFORMANCE AND CASCADED PROTECTION

Figure 3 shows results from the 120V sample. What we can see from this sample is that the clamp voltage consistently stays below the five times overvoltage level and actually decreases when the surge voltage decreases. Note that the last surge voltage was at a level below the UL VPR rating and still had the clamp voltage decrease.

Figure 4 shows the 480/277V sample. This sample performs much the same with the exception that the surge current decays much faster than that of the 120V sample. Based upon the performance of these two devices, we can conclude that the SPD will also protect equipment from lower voltage switching surges.

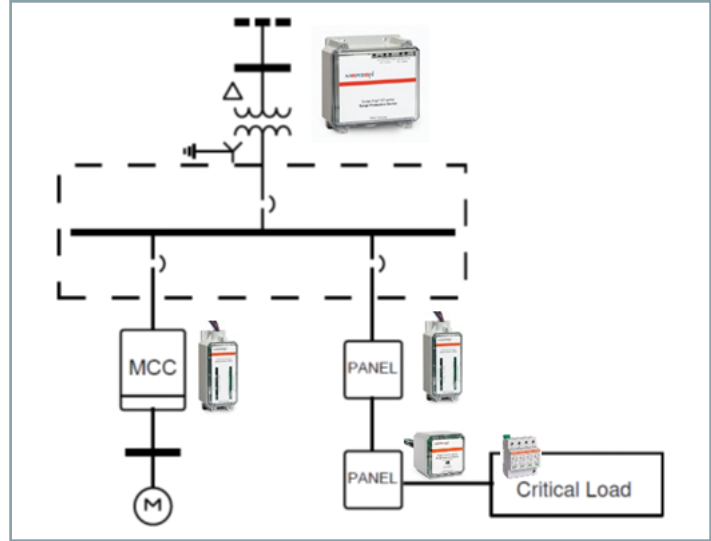

Figure 5: Cascaded SPD protection scheme

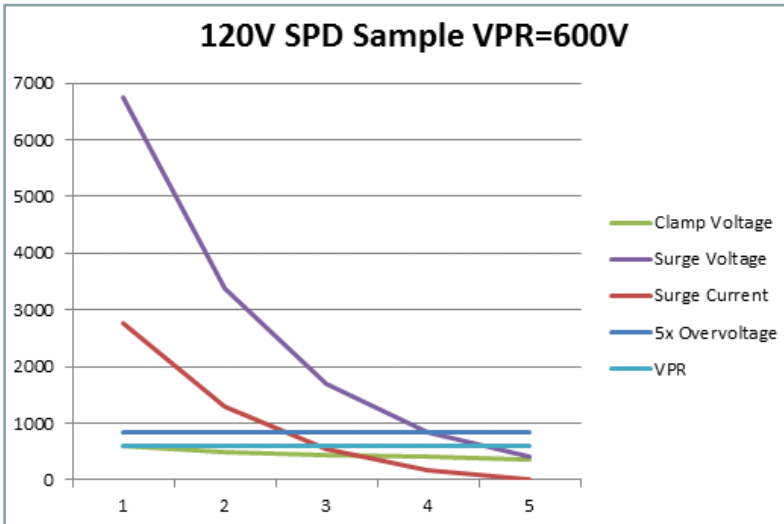

Figure 3: 120V sample test data graph

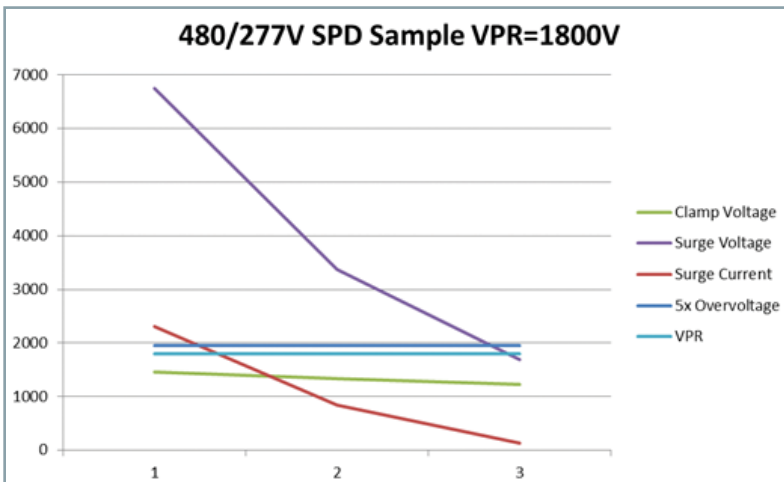

Figure 4: 480/277V sample test data graph

CASCADING SPD PROTECTION

In order to maximize system surge protection, system designers and owners often utilize cascaded surge protection. In a cascaded scheme, Surge Protective Devices are utilized in multiple locations throughout the power system. For example, there may be a SPD at the main service entrance, one at each distribution panel or gear, and one at each branch circuit panelboard. Critical equipment may also have SPDs installed on board for additional protection. See Figure 5 below for an example of cascaded protection. Cascading protection has the added benefit of quickly reducing switching surges produced within the facility and preventing them from affecting other equipment.

To help better understand the effectiveness of cascading, a test was conducted. The test began with a surge at 7kV with the resultant clamping voltage measured. The sample was then subjected to a surge approximately the value of the previous clamping voltage. This process was repeated until the change in voltage was negligible. Figures 6 and 7 on the next page show the results of the tests.

SURGE PROTECTIVE DEVICE PERFORMANCE AND CASCADED PROTECTION

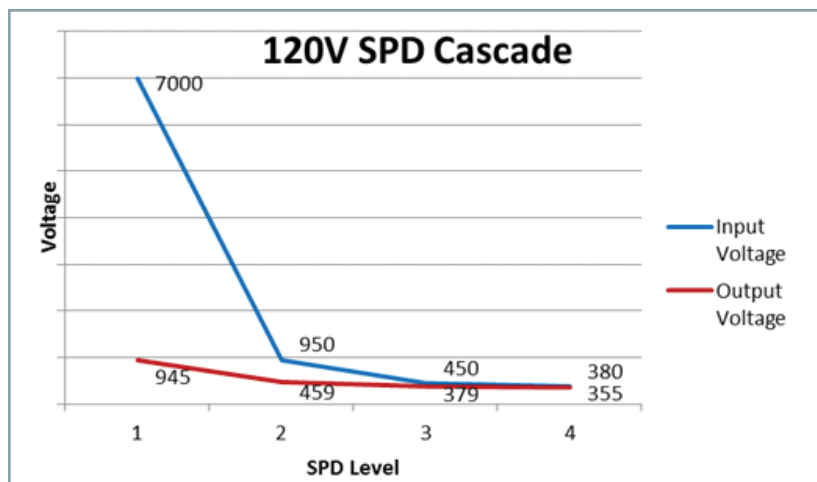

Figure 6: 120V Cascade Performance

For the 120V test, the first surge device would take the 7000V down to less than 1000V. Adding an additional device downstream would further reduce the surge to less than 500V. The third layer reduced the voltage by an additional 70V.

For the 480V test, the first level of protection reduces the output voltage to less than 2000V. An additional layer of protection can reduce the voltage by an additional 500V. In this situation, a third layer will cause an additional drop of 100V. The fourth layer gave an additional reduction in surge voltage of 40V.

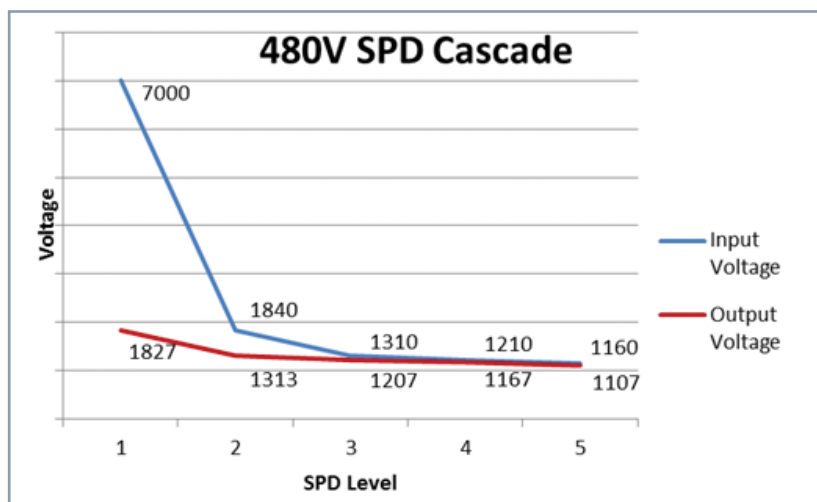

Figure 7: 480/277V Cascade Performance

RECOMMENDATIONS:

When selecting surge protective devices, it is important to choose devices which have the lowest possible voltage protection ratings in order to have the maximum reduction in surge voltages. VPR ratings must be less than 5x normal peak to be effective. Cascading protection is also very important to reduce large incoming surges to critical equipment as well as switching surges generated within a facility. A complete protection scheme will have SPDs located at strategic areas within the plant. Typically, 3-4 levels of SPD will offer the most protection. Critical loads should have on-board surge protection as a last line of defense.

CONTACT

USA

374 Merrimac Street, Newburyport, MA 01950
 T 978 462 6662 | F 978 462 0181
 info.nby@mersen.com

CANADA

6200 Kestrel Road, Mississauga, ON L5T 1Z1
 T 905 795 0077 | F 905 795 2508
 technicalservices.mis@mersen.com

TT-SPN7-001 | PDF | 3.18 | ©2018 Mersen. All rights reserved.

ADDITIONAL RESOURCES

Surge Protection Note 1: Introduction to Specifying Surge Protection

Surge Protection Note 2: Surge-Trap® and the Different kA Ratings

These and other Tech Topics are available on ep.mersen.com.