



# FUSE: SAFE & RELIABLE VS. CIRCUIT BREAKER

Franck Charlier  
Technical Support Engineer

In an industrial set-up the odds are clearly stacked in favor of the fuse. Safer, cheaper and more flexible when an installation changes, the fuse is the obvious choice for circuit protection.

### Points of interest:

- Power fuse needs no repair only to be replaced
- Power fuse improves the power quality in the system
- Selectivity is easy to manage between current limiting fuses

High operating voltages, many different lengths of wires and cables, and often widely varying feeders in the electrical configuration make an industrial-scale electrical layout very different from a residential installation. While the circuit breaker is undeniably the leading component in residential applications to protect against short-circuit currents and overloads, the fuse offers unquestionable advantages for equipment and installations in the industrial world.

### Up to 300,000 A

The capacity of fuses to break short-circuit currents is nothing short of extraordinary. Some industrial-scale fuses can clear currents up to 300,000 amps!

### Fast acting

### Lower cost

When everything is considered – purchase price, maintenance cost, foreseeable service life – a fuse proves to be much more economical than a circuit breaker. And that gap rapidly widens at higher ratings!

If only one property of fuses could be considered, it would have to be the exceptional speed with which they react to a fault. A few milliseconds are enough for a fuse to completely clear a short-circuit current, while the fastest circuit breaker in the limiter line takes 3 times as long. A more ordinary type of circuit breaker may take 30 times as long!

### Breaking capacity

Breaking capacity is defined as the highest short-circuit current the protective device is capable of stopping. Despite the undeniable progress made in the past few years, the circuit breaker soon shows its limits! For circuits running at 690V, a circuit breaker's breaking capacity is much too low to guarantee an installation's safety: while short-circuit currents may hit peaks of 100,000A at that voltage, a circuit breaker's breaking capacity may be less than 10,000A, which is clearly insufficient.



CMSFM10

### Safe

Safety is the vital feature of electrical equipment and installations. We're talking here about the safety of the men and women working around and on that equipment.

The very principle on which fuses operate argues in their favor. Inside the fuse body, a specially designed metal element melts down when current is too high. Nothing happens outside the fuse because the electrical arc created when the element melts is confined inside it and the energy is absorbed by the sand filling. Both people and property have a better guarantee of safety when an installation is equipped with fuses, as there is no risk whatsoever of equipment and machinery suffering any deterioration.

#### A word about maintenance

Again, there's a big difference between fuses and circuit breakers. Circuit breakers must be checked regularly to make sure the contacts are in good condition and the device operates correctly, while the fuse's extremely stable nature requires no work at all.

After a fuse has blown to clear a short circuit, it is simply removed and replaced with a new fuse, whereas a circuit breaker may need repair. For models with high current ratings, any parts that are damaged in operation must be replaced. Smaller ones may have to be entirely replaced after operating once or twice to deal with a fault. All that has a cost!

### Discriminating

Fuses are highly discriminating, as the fuse that is the smallest and closest to the short-circuit can act on the fault without involving any higher rated fuses up-line. With circuit breakers a system of selective coordination can be devised but is often difficult – or even impossible – to set up for short-circuit currents.



**MULTIBLOC 000.ST8**

## Relative advantages

<b>CIRCUIT-BREAKERS</b> (“mechanical moving parts”)		<b>FUSES</b> (“Nothing can prevent the fuse from blowing”) (Joule effect)
Although dimensions are standardized, there are many different tripping characteristics and forms of arc dispersion to the outside which complicates selection and replacement. MCBs have non adjustable characteristics, but up to 4 different type are available	International standardization means simplicity	IEC 60269 have electrical unit dimensional characteristics which make them fully interchangeable
<ul style="list-style-type: none"> <li>• Low performances</li> <li>• Hot ionized gases can be emitted to the outside (safety area needed)</li> </ul>	Fault current Current ( $I_N$ ) Nominal voltage ( $U_N$ ) Reliability Selectivity	<ul style="list-style-type: none"> <li>• High performances</li> <li>• Safe operation</li> </ul> ⇒ Confined arcing ⇒ Safely within the sealed cartridge

## Markets

- General market

User convenience ==> Domestic

### = Circuit-breakers

- Lower breaking capacity.
- Normally tested with additional length of cable

- Demanding market





Reliability ==> Industry

### = Fuses

- Have unrivalled ability to clear high fault currents safely. Breaking capacity up to 50 – 100 – 200 kA are common under the severest testing conditions.

- This means that detailed fault level calculations are not necessary. The fuse can do it !



## Comparison of motor starters

Fuse		Fonction	Circuit-breaker	
	Fuses	Short-circuit protection		Circuit-breaker
	Switch fuse isolation	Both polarities isolator of fuses		Contactor
	Contactor	Power control		Current transformer
	Overload relay	Overload protection		Switch disconnecter
	Switch disconnecter	Safety isolation (near Motor)		Motor
Motor	Motor			
Type 2		Co-ordination (IEC60947-4)	Type 1	
				

- Type 2 co-ordination shall be insured in order to comply with the safety rules (people and equipments). The fuse limits the peak current and let through  $I^2t$  to levels below the withstand of the contactor and overload relay.

- In case of motor starters with circuit-breaker protection, the contactor shall be over sized to carry the peak current through limiting breaker.

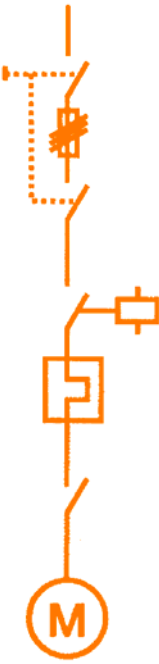
## Co-ordination test according to IEC60947-4

The tests for fuse protected starters	Possible consequences for wrong coordination	The tests for circuit breaker protected starters
<p>Test 1-30 kA Test 50 kA Test &lt; 10 le</p> 	<ol style="list-style-type: none"> <li>The peak let through current of the contactor leads to : light welding of the contactor contacts, damages of the arc chambers.</li> <li>The short circuit withstand current of the bimetal relay : exceeds maximum motor acceptable value burns the bimetal relay</li> <li>The peak let through current or <math>I^2t</math> in the circuit generates high electro-dynamics compulsions, high temperature rise (joule effect)</li> </ol>	<p>Test 1-30 kA Test 50 kA</p> 
For both fuses and breakers		

### Co-ordination type 1 :

- The starter and the contactor may be damaged.

### Co-ordination type 3 :

- The starter must be faultless after the tests.

### Co-ordination type 2 :

- The starter must be operable after the tests whatever high its prospective current may be.
- Only light welding of the contactor is allowed.
- Achievable with fuses whatever the contactor manufacturer is.
- With circuit-breaker, it is necessary to conduct tests and adjustments according to the manufacturer products.

**Current limiting and let through energy**

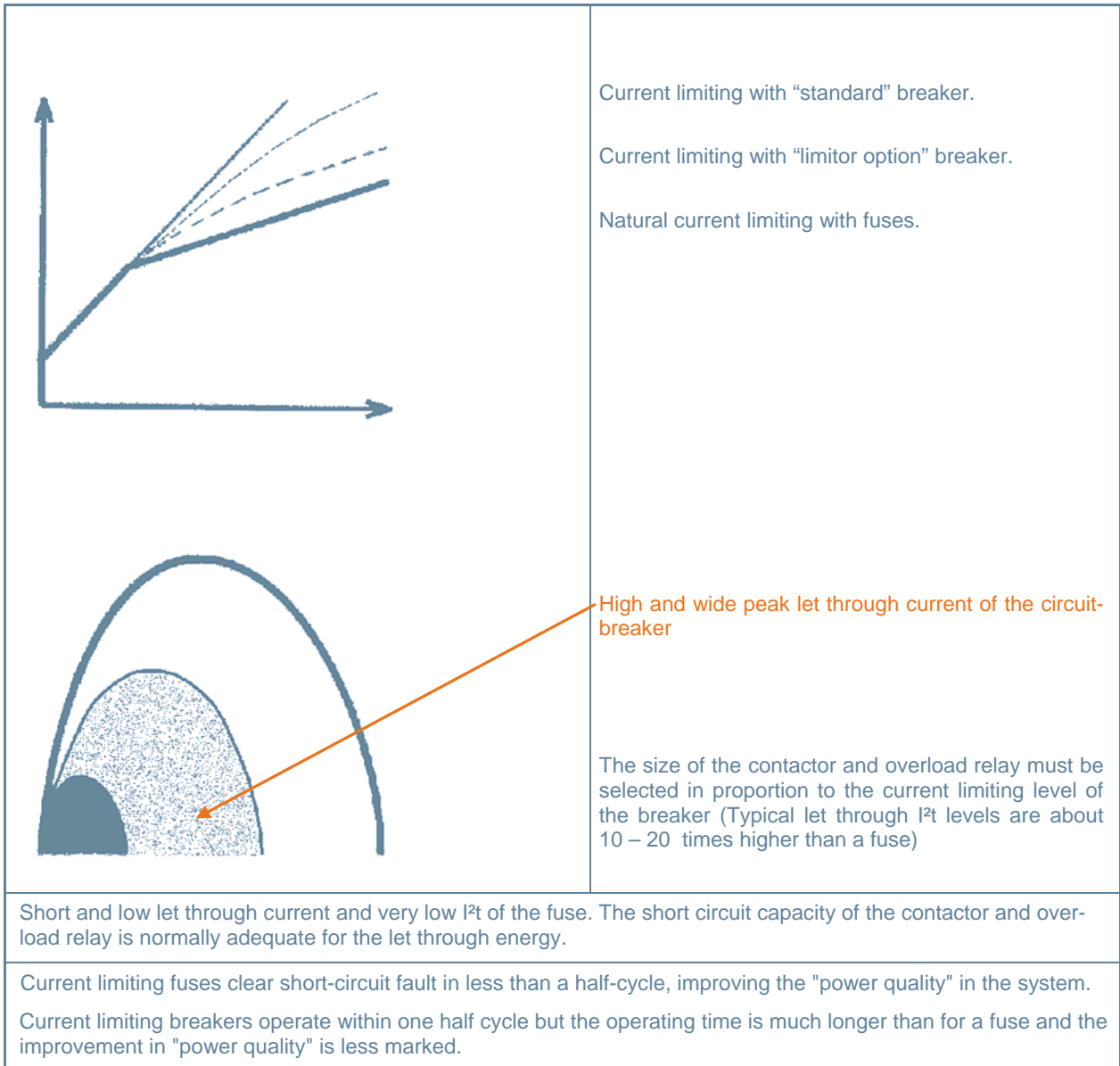

## Selectivity

**Fuses:** Excellent discrimination (selectivity) for all currents

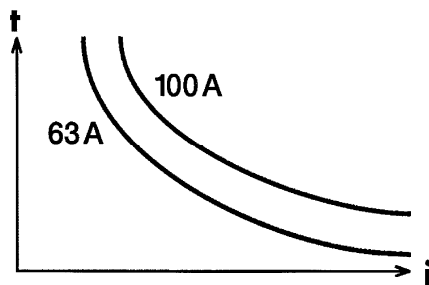

**Breakers:** Selectivity ensured for low currents

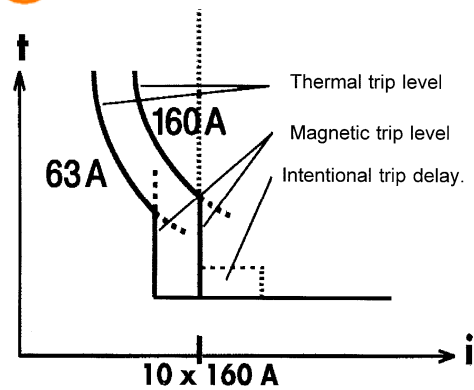

- Standard melting curve IEC 60269-1 and 2.
- Selectivity ratio = 1.6 / 1 with gG fuses.
- Selective when rated current of the fuse on supply side is one or two sizes higher than on load size.
- Specific let through energy in high currents is small. Contactor and thermal relay are not critically stressed.
- Always mechanical delay.
- Selectivity for high currents require specific calculations (often impossible to achieve).
- Time delay device improves selectivity only up to 15 times the rated current of the supply side breaker (selectivity ratio > 2.5/1 and usually 4/1 needed according characteristics).

## Selectivity Fuse / Circuit-breaker

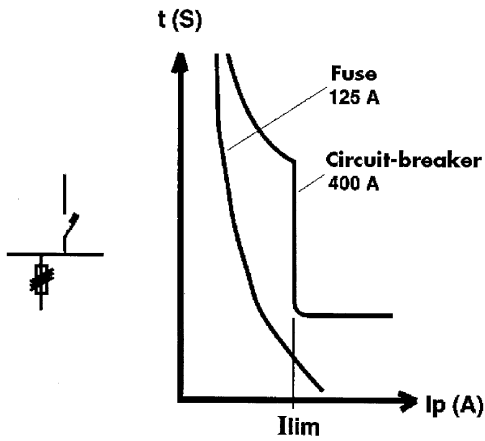

Require rated current higher for breaker than fuses (generally more than 3 times – to be controlled with instantaneous (Lim triggering action)).

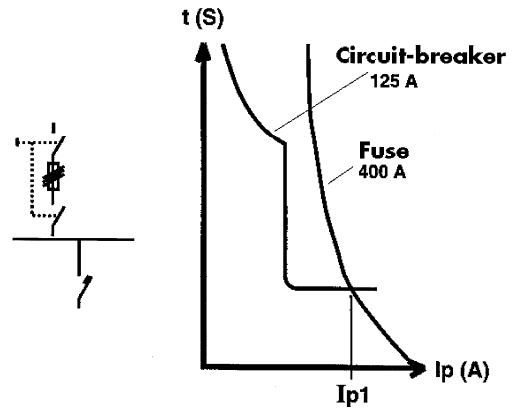

In this case the selectivity is not possible on the full range of currents ; the fuse will blow for high prospective currents.

In some cases, the fuses will permit to use low breaking capacity breaker (all currents higher than  $I_{p1}$  will be eliminated by fuse which has a very high breaking capacity).



### Reliable isolation

- When a fuse is removed from its holder or a switch fuse is operated "effective isolation" as required by IEC 60364 (wiring regulations) is achieved. In each case, when the fuses are removed, the circuit is open and the tripping distance is high. So that it is safe for persons to work on the downstream circuit.
- In addition, Mersen ITC and ITCP have reliable isolation on both sides of the fuse and the isolation has a visible point while fuses are removed.
- This increases safe operation for maintenance staff.
- Installation of a class AC22 or AC23 circuit-breaker, (break visible) or a class AC20 switch with a switching adjacent to the motor or the machine, with perfect security in the event of interference.
- The new machine regulations impose a switch with pe-breaking contact or a circuit-breaker to separate the energies (Clause R233-29), the electrical risks (Clause R233-25), the voluntary action of putting into operation (Clause 233-18).
- Only circuit breakers with a certain minimum contact separation will give effective isolation in accordance with the regulations. The case of reclosing a breaker increases the risk of accidental re-energisation of the circuit.

### Cost difference in use

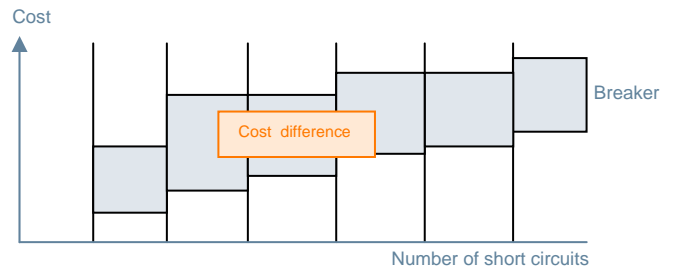

### Fuses

- Quick replacement (always three fuses on one circuit)
- Low spare part costs
- Ready for use after replacement

### Circuit-breaker

- Plug-in version is needed for quick replacement
- More costly spare part stock
- Require settings before use

## Performance and life time costs

	Fusegear		Breaker	
	Costs	Performance en %	Costs	Performance en %
<b>Investment</b>	1.0	100 %	1.2	100 %
<b>Failure n° 1</b>	0.1	100 %	0	80 %
<b>Failure n° 2</b>	0.1	100 %	0	60 %
<b>Failure n° 3</b>	0.1	100 %	1.2	100 %
	<ul style="list-style-type: none"> <li>• Safe replacement after operation ⇒ The system protection is re-stored to its original state.</li> <li>• Fuse totally closed : ⇒ Safe in minimum installation space ⇒ Long term protection perfect in various environmental conditions.</li> </ul>		<ul style="list-style-type: none"> <li>• Performance level drops in use</li> <li>• Not totally closed : ⇒ Space for overpressure needed ⇒ Smooth functioning must be skiller regular testing</li> </ul>	
	After a fault has occurred the cause of the fault must first be identified and then corrected. The fuse can be changed at this time.		Breaker must be changed after 2-3 major short-circuits with identical product (position of the venting on it not standardized).	

## Security if fault level increase

Electrical distribution net works grow with the addition of extra breakers and equipment :  
 eg. Second transformer is connected in parallel  
 ==> required higher breaking capacity devices.

**No problem with fuse system** (breaking capacity between 100 and 200 kA).

The breaking capacity of the breaker itself can be exceeded. In either case the breaker needs to be replaced with a more suitable type, or a fuse must be fitted to provide back-up protection of the breaker.

Present Situation		Future Situation
PN = 1250kVA		PN = 1250kVA
$U_{CC} = 4\%$		$U_{CC} = 4\%$
$I_{CCA} = 36,1kA$		$I_{CCA} = 72,2kA$
$I_{CCB} = 36,1kA$		$I_{CCB} = 72,2kA$

## Protection of cables

gG fuses to IEC 60-269... give complete over-current protection of cables in accordance with the international wiring regulations (IEC 60364)

- In accordance with IEC 60364 the section of the cables wire protected by fuses must be increased by 10 % (in comparison with circuit breaker protection with adjustable current).

On the other hand, this difference of section disappears in the following cases.

- \* Variation higher than 4% on the voltage supply
- \* Extensions
- \* Power losses calculated in the longer cables :

Ex : 50 m of 10 mm<sup>2</sup> cable for 60 A circuit == > R = 90 mohms == > power losses = 3900 kW / year  
 50 m of 16 mm<sup>2</sup> cable for 63 A fuses ==> R = 56 mohms ==> power losses = 2400 kW / year (depreciation in 4 years)

- Modern a fuses are tested at 1,3 IN in accordance with IEC 60269-2-1 standard
- Annexe ...and in order to have the same rating calculation than Circuit Breakers
- Circuit breakers can also provide low overcurrent protection of cables, but protection against short-circuit is only provided below a certain fault level